

Technical Data Sheet

SDC Rectifier/Battery Charger

- > 24–220 V
- > 25–1200 A



Gutor
is becoming
Schneider
Electric

Technical data SDC

Rectifier input

Voltage	3x380/400/415V
Input voltage tolerance:	
DC in tolerance	+/-10 %
for function	+15 % / -25 %
(below -15 % the battery might begin to discharge)	
Frequency	50/ 60 Hz
Frequency tolerance	+/- 8 %
Power factor:	
at nominal line power and float voltage	~ 0.83
at -10 % line power and float voltage	~ 0.90
at +10 % line power and float voltage	~ 0.75

DC output

Voltage	24/48/110/125/220VDC
Setting range:	
Float voltage at -10/+10 % line power voltage	100–120 %
Float voltage at 0/+10 % line power voltage	100–130 %
Boost voltage at nominal line power voltage	100–130 %
Initial charge voltage up to maximum	150 %
DC voltage tolerance	+/-1 %
Dynamic behavior:	
10–100 % and 100–10 % load step	maximum +/-10 %Vrms
regulation time	< 100 ms +/-2 %
DC ripple voltage	
Standard with parallel battery capacity of 3x nominal current:	
Optional without battery	≤2 % rms
Optional without battery	≤1 % rms
Optional without battery (24/48V)	≤2mV (at 800 Hz, psophometric)
DC current	according to type range
Setting range:	
Total output current limitation	50–100 %
Battery current limitation	0–100 %
DC current tolerance	+/-2 %
Characteristic	I-U according to DIN 41773
DC overcurrent capability	150 % for 2s

General data

Ambient conditions	
Storage temperature range	from -20 to +70 °C
Operating temperature range	from -10 to +40 °C
Altitude above sea level	1000 m
Allowable air humidity	<95 % (non condensing)
Noise level standard n+1 fans	55–65 dBA
Noise level 100 % redundant fans	65–70 dBA
Degree of protection	IP20 according to IEC 60529
Paint	Pebble gray, RAL 7032 structured
Standards:	
Safety	IEC/EN 62040-1-2
EMC	IEC 62040-2, EN 50091-2
Performance	IEC/EN 62040-3, IEC 60146-1-1
Conformity	CE-Label
Efficiency	up to 94 % depending on type
Cooling	Natural convection up to 100A/220V and top forced-air ventilation with redundant n+1 monitored fans

Data subject to change

Specification SDC

Typical single-line drawing

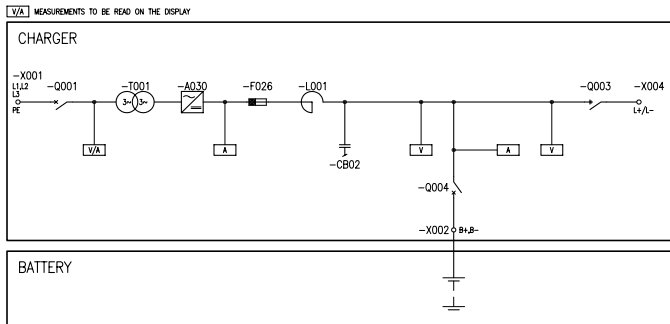

Output voltage & output current

Output voltage (VDC)	24	48	110	125	220
DC Output current (A)	-	-	-	-	25
	-	-	50	50	50
	-	100	100	100	100
	-	125	125	125	125
	-	160	160	160	160
	200	200	200	200	200
	250	250	250	250	250
	315	315	315	315	315
	400	400	400	400	400
	500	500	500	500	500
	630	630	630	630	630
	800	800	800	800	800
	1000	1000	1000	1000	1000
1200	1200	1200	1200	1200	

Standard configuration

Single system	
Rectifier input voltage	3x400V +10/-10
Rectifier input frequency	50 Hz +/- 8%
Ripple filter	≤2% rms with parallel battery
6-pulse Rectifier with Isolation Transformer	
Rectifier input switch	
Fixed charging voltage IU characteristic	
System front panel w. mimic and add. LEDs for direct alarm display	
LCD display unit with keyboard	
External connection board:	
Common alarm	2x NO/NC
Charger failure	NO/NC
Remote ON/OFF	
Emergency stop	(internal or external power supply)
Input to activate boost charge	
Input to activate initial charge	
Input to inhibit boost and initial charge	
Connection for battery temperature sensor	
Input for signaling battery fuse/MCCB	
Connection for remote display	
RS232 Interface	(event log download)
Battery capacity test	(full discharge with current load)
DC ground fault alarm	

Bottom cable entry

Ground terminal

N+1 monitored two-speed fans (above 100A)

Ambient temperature range from -10 to +40 °C

Options

Parallel redundant configuration with load sharing

Other input voltages (190–690 V)

Rectifier input frequency 60 Hz +/- 8%

Ripple filter

≤ 1% rms without battery

≤ 2% rms without battery

≤ 2mV (at 800 Hz, psophometric)

12-pulse rectifier with isolation transformer

Rectifier input MCCB

Sensor & cable for temperature-dependent battery charging, recommended for sealed VRLA batteries and wide temperature range

Battery temperature alarm (with above sensor and cable)

Serial diode (for parallel rectifiers)

Rectifier output isolator

Rectifier output circuit breaker

Battery fuse in rectifier

Battery fuse box

Battery MCCB in rectifier

Battery MCCB box

Additional analog meters 96x96, cl. 1.5

Relay board, 16 failsafe NO/NC contacts:

Charger ON 4x programmable

Boost charge ON Fan fault

Line power failure DC current overload

DC out of tolerance Internal PSU fault

Battery discharged DC ground fault

Battery disconnected Overtemperature

DC fuse blown

Extended overload

Advanced battery monitor (programmable battery data)

Battery asymmetry supervision

RS-485 Interface

RJ-45 Ethernet port for Web browser based monitoring

RS-485 MODBUS Protocol (slave)

External time synchronization

Top cable entry

Top and bottom cable entry

Ventilation 100% redundant

Space heaters

Panel lighting

Ambient temperature maximum +55 °C

Allowable altitude < 4000 m above sea level

Air filters at air inlet

Protection up to IP52 (NEMA 12)

Seismic design

Aging tests

Other colors

Additional options are available on request

Human-machine interface (front panel)

The front panel, which is identical for both AC and DC Systems, includes a comprehensive and flexible human-machine interface. It is divided into four sections:

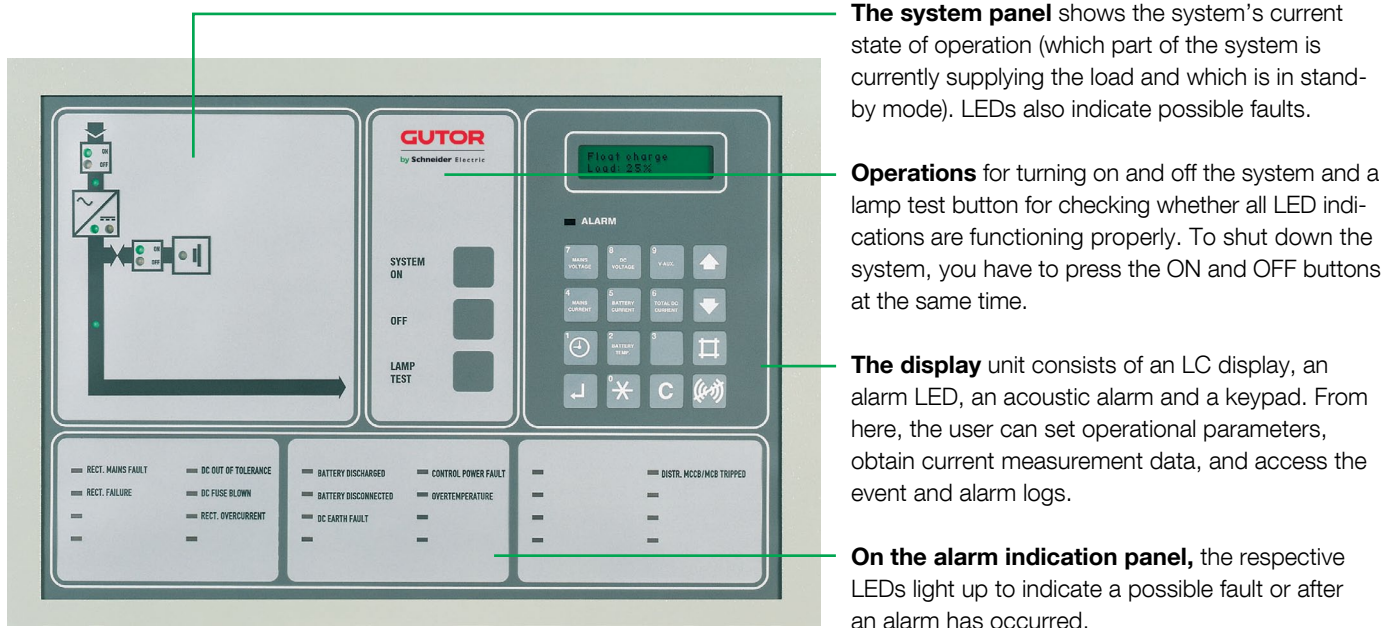

The system panel shows the system's current state of operation (which part of the system is currently supplying the load and which is in stand-by mode). LEDs also indicate possible faults.

Operations for turning on and off the system and a lamp test button for checking whether all LED indications are functioning properly. To shut down the system, you have to press the ON and OFF buttons at the same time.

The display unit consists of an LC display, an alarm LED, an acoustic alarm and a keypad. From here, the user can set operational parameters, obtain current measurement data, and access the event and alarm logs.

On the alarm indication panel, the respective LEDs light up to indicate a possible fault or after an alarm has occurred.

Operational parameters

Selectable second display language

Auto start

Charge mode (float/boost/initial)

Auto boost charge

Battery capacity test

Advanced battery monitor test (optional)

Set date/time

Indication & measurements

Operating mode (float/boost/initial)

DC total current

Battery voltage and current

AC Rectifier line power voltage and current

Battery temperature (with optional sensor)

Time left in battery operation with current load (option only with advanced battery monitoring)

Event log with date/time (operating mode changes and alarms)

GUTOR
by Schneider Electric

GUTOR Electronic LLC

Hardstrasse 72-74

5430 Wettingen

Switzerland

P +41 (0)56 437 34 34

F +41 (0)56 437 34 44

gutor.info@schneider-electric.com

www.gutor.com

Offices

Brazil > Canada > China > Germany > India

Japan > Malaysia > Mexico > Russia > Saudi Arabia

United Arab Emirates > USA