



2400 Tapping Machine

Sizes: 30- Through 60-inch Standard Model and XL Model



T.D. Williamson, Inc.

Bulletin No: 1000.002.00

Date: July 1998

Cross Indexing No: n/a

Supersedes: 406 (3/91)



■ 2400 Tapping Machine

Description

Tapping machines are used for making connections to pipelines, tanks, and plant piping without shutdown and are used to make hot taps in preparation for plugging machine applications.

Model 2400 tapping machines are designed to make hot taps into metal pipe, tank tops and walls. It is hydraulically operated and is used for making pipe and tank taps from 30" to 60". Its operating temperature is -20°F (-29°C) to 200°F (93°C) at 1,200 psi (82 bar).

Features

The basic machine includes:

- Tapping machine
- Ladder and platform
- Hydraulic Piping
- Skid
- Connecting hoses
- Power unit
- Twin-drive motors
- Feed motor

Options*

T. D. Williamson, Inc., is committed to providing you with the exact product to assist you in planning, budgeting and meeting the specifications for your individual application needs.

■ The hydraulically powered 2400 has an optional electronic remote control system. The remote control unit gives the operator the advantage of remaining inside a temperature-controlled building while completing jobs in extreme climate conditions.

* For design code options not listed and additional sizes, consult your sales representative.

Patented in the United States and in foreign countries.
ISO 9001 Certified

Toll Free

1-888-TDWmSon (839-6766)

■ Typical Tapping Setup

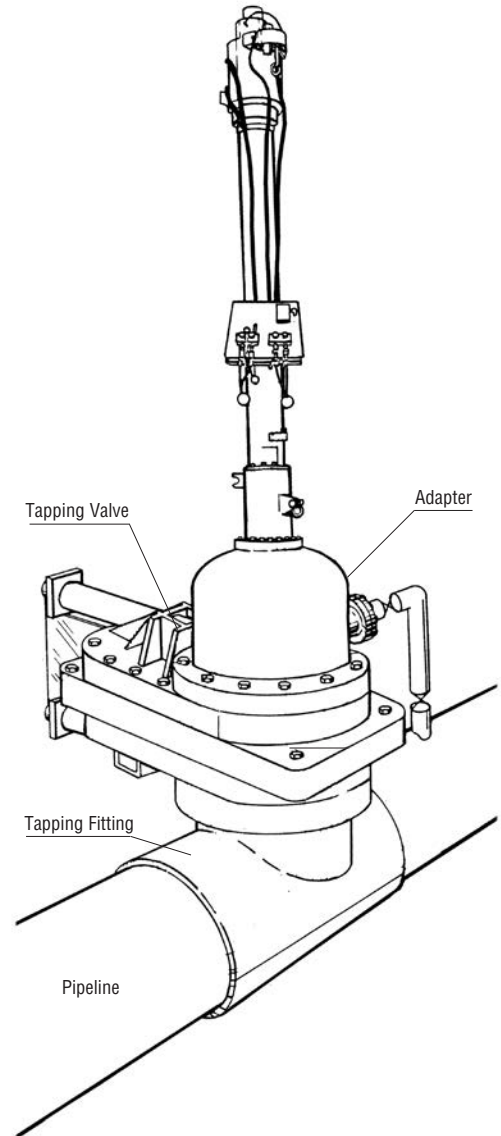



T.D. Williamson, Inc.

1000.002.00- p2

Specifications

2400 Tapping Machine *Standard Model and XL Model*

Specifications

Maximum operating pipeline pressure	1200 psig (83 bars) at 200°F
Maximum operating temperature range (in pipeline)	-20°F to +200° F (-29°C to 93°C) at 1200 psi
Maximum operating hydraulic pressure	1800 psi (138 bars)
Maximum boring bar travel	Standard 108 inches (2,743 mm) variable feed or XL 130 inches (3302 mm) variable feed
Rate of travel	adjustable to 6 ipm (152 mm per min.)
Feed rate	adjustable to 0.125 inches per revolution (3.2 mm per rev.)
Minimum size tap	30 inches (760 mm) (24" special application)*
Maximum size tap (size on size)	60 inches (1520 mm)
Weight of tapping machine (with hydraulic manifold assembly)	Standard 7500 lbs. (3409 kg); XL 8000 lbs. (3632 kg.)
Weight of hydraulic hoses	435 lbs. (198 kg)
Basic machine (without adapter)	193.875 inches (4925 mm)
Hoses (5 on reels)	each 50 feet (15 meters)
Tapping positions	vertical and horizontal
Operation	electronically controlled hydraulic system
LOCK-O-RING® Plug setting	vertical — consult factory for other positions
Coupon retention system	positive
Boring bar RPM	variable, 0 to 18 RPM
Anti-stall feature	stall reverses feed

Power Unit

Weight of power unit	4100 lbs. (1860 kg)
Engine	Model 5034 - 7201 (3-53) Detroit Diesel 88 HP @ 2500 RPM. Fuel tank capacity 30 gallons (113.5 liters)
Pump	Tandem Pumps

Tapping machine

Lubrication	Dow Corning BR2S or equivalent; Lithium base NLGI No. 2 extreme pressure with 3% MoS ₂ grease. (Ambient temperature above 0°F, or -180°C.) Mobil Grease 28, or equivalent; Low temperature NLGI No. V/2 to No. 2 extreme pressure grease. (Ambient temperature below 0°F, or -180°C.)
-------------	---