



## *Control Valves & Regulators*

*Sliding Gate Valves*

*Pressure Regulators*

*Temperature Regulators*

*Control Valves*

*Positioners*



Jordan Valve sliding gate regulators and control valves are excellent choices for many of your process and utility applications. They consistently deliver reliable and superior performance at low ownership cost.

Jordan Valve not only offers a broad range of standard body/trim materials, but also exotic materials when service conditions dictate the need for greater chemical resistance.

Jordan valve engineers and manufactures products that consistently outperform the competition. Our revolutionary Jorcote coating on sliding gate seats and our PTFE based Jorlon diaphragms combine to give outstanding reliability and service life.

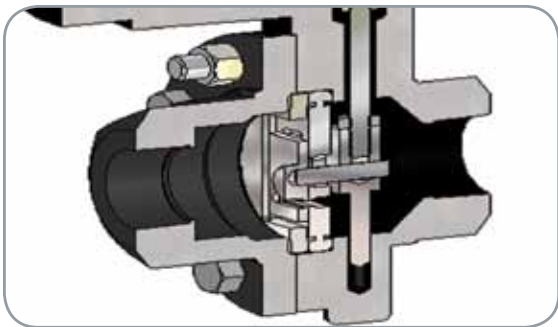

## Sliding Gate Valves

The sliding gate is a simple concept that traces its origin back to the sliding valve used in the Corliss steam engine. This technology offers high capacity with straight through flow in a compact design.

The sliding gate is made up of two parts: a stationary plate with multiple orifices and a disc that moves across the face of the plate. When open, the orifices of the plate and disc match so that flow can move through the seats. When closed, the disc and plate provide a solid barrier to flow.

The sliding gate offers the following benefits:

- **Short stroke:** The total stroke length of a sliding gate valve is a fraction of the equivalent globe valve. This results in less droop and longer life in a regulator and faster response in a control valve. The short stroke also results in improved packing life, thereby reducing the overall cost of maintenance and ownership.
- **Quiet Operation:** Since the disc is in constant contact with the plate (aided by upstream pressure), there is no chatter when compared to conventional plug valves. The straight through flow reduces turbulence through the valve resulting in quieter operation.
- **Tight Shutoff:** The sliding gate provides an area of closure instead of a line of closure as in most globe style valves. The orifices of the plate are overlapped by the disc by 1/32". This results in longer seat life and less maintenance costs.
- **Interchangeable Seats:** Valve flow coefficients can be easily changed in the field. Disassembly is easy, and since the seats are not screwed or welded in, they simply lift out of the body. On control valves, the action of the valve (ATC / ATO) can be changed by rotating the seats 180°.

### Jorcote Seat Material

Jordan Valve offers a variety of coatings and seat materials to meet almost any application need.

Jorcote, our standard seat material, is a proprietary composite coating on Stainless Steel. This material is extremely hard (@ RC85) and delivers outstanding performance. Factory testing at 250 psi steam shows that after over 70,000 full stroke cycles, Jorcote will still shutoff well below ANSI Class IV leak limits. Other coatings include Jordanic, Teflon coating, and chrome plating.

### Jordan Valve Express

Many of our standard Jordan Valve products are available for next day shipment at no additional charge.

Please contact the factory for a complete listing.

### Customization

In addition to the standard models featured on the pages that follow, Jordan Valve engineers welcome the opportunity to engineer products for your specific application.



### Jorlon Diaphragm

If you are looking to extend the life of your regulators and reduce the overall cost of ownership, then look no further than Jordan Valve's Jorlon diaphragm. This diaphragm was developed as an alternative to the standard SST diaphragm and offers several distinct advantages.

Jorlon is a proprietary modified PTFE material that positively impacts regulator reliability, performance, and service life. It is the standard and preferred diaphragm in most regulator applications and provides the following benefits:

- **Chemical Compatibility:** Since Jorlon is PTFE based, it is compatible with the same media as Teflon up to 450°F.
- **Improved Performance:** SST diaphragms by nature are rigid and therefore have decreased sensitivity. Jorlon approaches the droop performance seen in true elastomer diaphragms resulting in greater set point accuracy.
- **Long Life:** Jorlon has been extensively tested at the factory for durability. The diaphragm was tested on both 300 psi air and 450°F steam with no failures...even after over 1,000,000 full stroke cycles.
- **Lower Ownership Costs:** Less droop means better accuracy, and better accuracy means better overall performance and productivity. Its long life means less down time to replace a failed diaphragm which translates into higher profits.
- **High Pressure Limits:** Jorlon has been tested in excess of our regulators maximum allowable pressures. In some cases, Jorlon can be rated as high as 720 psi at 100°F.

Jorlon is indeed the diaphragm of choice for almost every regulator application. Combine the long life of Jorlon with the superior characteristics of Jorcote, and you end up with a regulator that will outlast most systems with normal use.

## Sliding Gate Regulators

### Mark 60/61 Series Self-Operated Pressure Regulators



The Mark 60 handles a broad range of applications including steam, water, oil, gas, air and chemicals. It features the Sliding Gate seat which combines excellent control and extreme longevity in a compact, lightweight design. The Mark 61 features a larger diaphragm to provide greater sensitivity.

- Shutoff – ANSI Class IV shutoff
- Sizes: Mk 60: 1/4" – 4" (DN8 – DN100); Mk 61: 1/4" – 3/4" (DN8 – DN20)
- Body Materials: Ductile Iron, Bronze, Carbon Steel, Stainless Steel, Cast Iron
- End Connections: Threaded, Flanged, Socket Weld, Butt-Weld
- Cv (Kv): up to 200 (up to 172)
- Trim Materials: Stainless Steel, Monel, Hastelloy C, Alloy 20
- Diaphragm: Jorlon, Stainless Steel, Buna-N, Viton
- Setpoints: 1 to 450 psi (0,07 to 31,0 bar)

### Mark 601/602 Series High-Flow Pressure Regulators



The high-flow MK601 and MK602 are used for applications that require a higher Cv rating without using a larger valve. Jordan's Sliding Gate seats, help reduce the droop commonly associated with high flow regulators.

- Shutoff – ANSI Class IV shutoff
- Sizes: 1-1/2" through 2" (DN40 through DN50)
- Body Materials: Ductile Iron, Bronze, Carbon Steel, Stainless Steel
- End Connections: Threaded, Flanged, Socket Weld, Butt-Weld
- Cv (Kv): up to 70 (up to 60)
- Trim Materials: Stainless Steel, Monel, Hastelloy C, Alloy 20
- Diaphragm: Jorlon, Stainless Steel, Buna-N, Viton
- Setpoints: 20 to 160 psi (1,4 to 11,0 bar)

### Mark 63/64 Series Differential Pressure Regulators



The Mark 63 is designed to maintain a constant differential between the pressure on the discharge side of the regulator and the signal pressure loaded on the diaphragm. The Mark 64 provides the same flow capacity but with less offset. It features a larger effective diaphragm area for greater sensitivity.

- Shutoff – ANSI Class IV shutoff
- Sizes: MK 63: 1/4" – 2" (DN8 – DN50); MK 64: 1/4" – 3/4" (DN8 – DN20)
- Body Materials: Ductile Iron, Bronze, Carbon Steel, Stainless Steel
- End Connections: Threaded, Flanged, Socket Weld, Butt-Weld
- Cv (Kv): up to 30 (up to 25,8)
- Trim Materials: Stainless Steel, Monel, Hastelloy C, Alloy 20
- Diaphragm: Stainless Steel, Jorlon, Buna-N, Viton
- Setpoints: 1 to 450 psi (0,07 to 31,0 bar)

## Sliding Gate Regulators

### Mark 65 Series Downstream Vacuum Regulators

Jordan downstream vacuum regulators control very accurately to maintain the proper vacuums at predetermined settings and to regulate vacuums on evaporators, cookers, grinding fixtures, milking machines, altitude chambers and other vacuum systems.

- Shutoff – ANSI Class IV shutoff
- Sizes: 1/2" through 6" (DN15 through DN150)
- Body Materials: Ductile Iron, Bronze, Carbon Steel, Stainless Steel, Cast Iron
- End Connections: Threaded, Flanged, Socket Weld, Butt-Weld
- Cv (Kv): up to 395 (up to 340)
- Trim Materials: Stainless Steel, Monel, Hastelloy C, Alloy 20
- Diaphragm: Jorlon, Stainless Steel, Buna-N, Viton
- Service: Steam, water, air, gas, oil, chemicals



### Mark 66 Series Air Loaded Pressure Regulators

The Jordan Mark 66 is one of the most accurate pressure regulators on the market. The convenience of dome loading and the sliding gate provide excellent regulation and rangeability. Can be coupled with an extended range I/P for remote operation. Can also be manually controlled with a MK12 loading station or JR regulator.

- Shutoff – ANSI Class IV shutoff
- Sizes: 1/2" through 6" (DN15 through DN150)
- Body Materials: Ductile Iron, Bronze, Carbon Steel, Stainless Steel, Cast Iron
- End Connections: Threaded, Flanged, Socket Weld, Butt-Weld
- Cv (Kv): up to 395 (up to 340)
- Trim Materials: Stainless Steel, Monel, Hastelloy C, Alloy 20
- Diaphragm: Jorlon, Stainless Steel, Buna-N, Viton
- Setpoints up to body ratings



### Mark 67 Series Pilot-Operated Pressure Regulators

The Mark 67 is for critical pressure reducing applications and provides greater accuracy and lower offset than can be achieved with a self-operated regulator. The Sliding Gate seats provides unsurpassed seat and diaphragm life, ease of installation, simplified maintenance and more accurate performance.

- Shutoff – ANSI Class IV shutoff
- Sizes: 1/2" through 6" (DN15 through DN150)
- Body Materials: Ductile Iron, Carbon Steel, Stainless Steel, Cast Iron
- End Connections: Threaded, Flanged, Socket Weld, Butt-Weld
- Cv (Kv): up to 395 (up to 340)
- Trim Materials: Stainless Steel, Monel, Hastelloy C, Alloy 20
- Diaphragm: Stainless Steel, Monel, Hastelloy C, Alloy 20
- Setpoints: 10 to 200 psi (0,69 to 13,79 bar)



## Sliding Gate Regulators

### Mark 50/51 Series Self-Operated Back Pressure Regulators



The Mark 50/51 handles a broad range of applications including steam, water, oil, gas, air and chemicals. Excellent capacity and the sliding gate trim enable the Mark 50 to quickly and accurately regulate upstream pressure, preventing overpressure situations. The Mark 51 features a larger diaphragm for greater sensitivity.

- Shutoff – ANSI Class IV shutoff
- Sizes: MK 50: 1/4" – 4" (DN8 – DN100); MK 51: 1/4" – 3/4" (DN8 – DN20)
- Body Materials: Ductile Iron, Bronze, Carbon Steel, Stainless Steel, Cast Iron
- End Connections: Threaded, Flanged, Socket Weld, Butt-Weld
- Cv (Kv): up to 200 (up to 172)
- Trim Materials: Stainless Steel, Monel, Hastelloy C, Alloy 20
- Diaphragm: Jorlon, Stainless Steel, Buna-N, Viton
- Setpoints: 0.5 to 450 psi (0,03 to 31,0 bar)

### Mark 501/502 Series High-Flow Back Pressure Regulators



The high-flow MK501 and MK502 are used for applications that require a higher Cv rating without going to the next highest line size. Jordan's Sliding Gate seats, help reduce the build-up commonly associated with high flow back pressure regulators.

- Shutoff – ANSI Class IV shutoff
- Sizes: 1-1/2" through 2" (DN40 through DN50)
- Body Materials: Ductile Iron, Bronze, Carbon Steel, Stainless Steel
- End Connections: Threaded, Flanged, Socket Weld, Butt-Weld
- Cv (Kv): up to 70 (up to 60,2)
- Trim Materials: Stainless Steel, Monel, Hastelloy C, Alloy 20
- Diaphragm: Jorlon, Stainless Steel, Buna-N, Viton
- Setpoints: 0.5 to 150 psi (0,03 to 10,3 bar)

### Mark 53/54 Series Differential Back Pressure Regulators



The Mark 53 is designed to maintain inlet pressure at a set differential pressure over the signal pressure loaded on the diaphragm. The Mark 54 provides the same flow capacity as the Mark 53 but with less offset in controlled pressure due to a larger diaphragm.

- Shutoff – ANSI Class IV shutoff
- Sizes: MK 53: 1/4" – 2" (DN8 – DN50); MK 54: 1/4" – 3/4" (DN8 – DN20)
- Body Materials: Ductile Iron, Bronze, Carbon Steel, Stainless Steel
- End Connections: Threaded, Flanged, Socket Weld, Butt-Weld
- Cv (Kv): up to 30 (up to 25,8)
- Trim Materials: Stainless Steel, Monel, Hastelloy C, Alloy 20
- Diaphragm: Jorlon, Buna-N, Viton
- Setpoints: 0.5 to 450 psi (0,03 to 31,0 bar)

## Sliding Gate Regulators

### Mark 55 Series Upstream Vacuum Regulators

The Mark 55 upstream regulators control very accurately to maintain the proper vacuums at predetermined settings and to regulate vacuums on evaporators, cookers, grinding fixtures, milking machines, altitude chambers and other vacuum systems.

- Shutoff – ANSI Class IV shutoff
- Sizes: 1/4" through 2" (DN8 through DN50)
- Body Materials: Ductile Iron, Bronze, Carbon Steel, Stainless Steel
- End Connections: Threaded, Flanged, Socket Weld, Butt-Weld
- Cv (Kv): up to 30 (up to 25,8)
- Trim Materials: Stainless Steel, Monel, Hastelloy C, Alloy 20
- Diaphragm: Jorlon, Stainless Steel, Buna-N, Viton
- Setpoints: 1" to 25" Hg vacuum (0,035 to 0,886 kg/cm<sup>2</sup>)



### Mark 56 Series Air Loaded Back Pressure Regulators

The Mark 56 is one of the most accurate back pressure regulators on the market. The convenience of dome loading and the sliding gate seat provide excellent regulation and rangeability. Can be coupled with an extended range I/P for remote operation. Can also be manually controlled with a MK12 loading station or JR regulator.

- Shutoff – ANSI Class IV shutoff
- Sizes: 1/2" through 6" (DN15 through DN150)
- Body Materials: Ductile Iron, Bronze, Carbon Steel, Stainless Steel, Cast Iron
- End Connections: Threaded, Flanged, Socket Weld, Butt-Weld
- Cv (Kv): up to 395 (up to 340)
- Trim Materials: Stainless Steel, Monel, Hastelloy C, Alloy 20
- Diaphragm: Stainless Steel, Jorlon, Buna-N, Viton
- Setpoints: up to body rating



### Mark 57 Series Pilot-Operated Back Pressure Regulators

The Mark 57 pilot operated back pressure regulator is designed to accurately control pressure to 100% of its rated flow capacity with only a small deviation from setpoint. The Mark 57 provides accuracy that approaches that of controller-operated valves.

- Shutoff – ANSI Class IV shutoff
- Sizes: 1/2" through 6" (DN15 through DN150)
- Body Materials: Ductile Iron, Carbon Steel, Stainless Steel, Cast Iron
- End Connections: Threaded, Flanged, Socket Weld, Butt-Weld
- Cv (Kv): up to 395 (up to 340)
- Trim Materials: Stainless Steel, Monel, Hastelloy C, Alloy 20
- Diaphragm: Stainless Steel
- Setpoints: 25 to 185 psi (1,7 to 12,8 bar)



## Globe and Cage Style Regulators

### Mark 68G Series Pressure Regulators



The Mark 68G offers high capacity, accurate regulation, and easy servicing, making it the ideal choice for your industrial-grade pressure reducing applications. The MK68G can be supplied with a soft seat to provide ANSI Class VI shutoff.

- Shutoff: ANSI Class IV (hard seat); ANSI Class VI (soft seat)
- Seat: Plug – Buna-N, Viton, Hardened 17-4 pH Stainless Steel
- Sizes: 1/4" through 2" (DN8 through DN50)
- Body Materials: Ductile Iron, Bronze, Carbon Steel, Stainless Steel
- End Connections: Threaded, Flanged, Socket Weld
- Cv (Kv): up to 19 (up to 16,3)
- Trim Material: Stainless Steel
- Diaphragm: Stainless Steel, Jorlon, Buna-N/Nylon, Viton/Nomex

### Mark 686 Series Air-Loaded Cage Trim Pressure Regulators



The Mark 686 features air-loading, high capacities, accurate regulation and easy servicing, making it an exceptional choice for your pressure regulating applications. The MK686 is excellent when remote and/or frequent setpoint adjustment is required.

- Shutoff: ANSI Class IV (hard seat); ANSI Class VI (soft seat)
- Seat: Plug – Buna-N, Viton, Hardened 17-4 pH Stainless Steel
- Sizes: 1/4" through 2" (DN8 through DN50)
- Body Materials: Ductile Iron, Bronze, Carbon Steel, Stainless Steel
- End Connections: Threaded, Flanged, Socket Weld
- Cv (Kv): up to 19 (up to 16,3)
- Cage Materials: Stainless Steel
- Diaphragm: Stainless Steel, Jorlon, Buna-N/Nylon, Viton/Nomex

### Mark 58 Series Cage Trim Back Pressure Regulator



The Mark 58 features three ports: a bypass outlet on the bottom, and two side ports which are directly connected to serve as dual inlet and outlet for through-flow

- Shutoff: ANSI Class IV (hard seat); ANSI Class VI (soft seat)
- Seat: Plug – Buna-N, Viton, EPDM, 17-4 PH Stainless Steel
- Sizes: 1/4" through 2" (DN8 through DN50)
- Body Materials: Ductile Iron, Bronze, Carbon Steel, Stainless Steel
- End Connections: Threaded, Flanged, Socket Weld
- Cv (Kv): up to 32.4 (up to 27,86)
- Cage Materials: Electro-nickel plated steel or Stainless Steel depending on body material
- Diaphragm: Stainless Steel, Jorlon, Buna-N/Nylon, Viton/Nomex



## Gas Regulators

### Mark 608IS Series Gas Pressure Regulators (3/4" – 1-1/4")

The Mark 608IS gas pressure regulator is the ideal valve for low pressure gas regulation. The self-contained low pressure gas regulator is for use on tank blanketing, gas meter inlet pressure regulating, gas burners and other low pressure air and gas applications.

- Shutoff: ANSI Class VI
- Sizes: 3/4" through 1-1/4" (DN20 through DN32)
- Body Materials: Carbon Steel, Stainless Steel, Ductile Iron
- End Connections: Threaded, Flanged
- Trim Materials: Stainless Steel
- Plug: Buna-N and Stainless Steel (DI body); Stainless Steel and Viton (CS & SS body)
- Setpoints:
- Maximum Inlet Pressure: 150 psi (10,3 bar)



### Mark 608DS Series Low Pressure Double Seated Gas Regulator (1-1/2" – 2")

The Mark 608DS is a double-seated, self-operated gas regulator for use in tank blanketing applications. The double seated design allows the Mark 608DS to handle increased flow and higher pressure drops than similarly sized single seat valve types while maintaining ANSI Class VI shutoff.

- Shutoff – ANSI Class VI
- Sizes: 1-1/2" – 2" (DN40 – DN50)
- Body Materials: Carbon Steel, Stainless Steel
- End Connections: ANSI 150/300 Integrally Flanged
- Trim Materials: Stainless Steel
- Diaphragm:
- Cv (Kv): 1-1/2": 5 Cv; orifice 9/16"; 2": 17 Cv; orifice 1"
- Maximum Inlet Pressure: 150 psi (10,3 bar)



### Mark 608BP Series Balanced Plug Gas Pressure Regulators

The Mark 608BP balanced plug gas pressure regulator is the ideal valve for low pressure gas regulation with higher inlet pressures. The self-contained low pressure gas regulator is for use on tank blanketing, gas meter inlet pressure regulating, gas burners and other low pressure air and gas applications.

- Shutoff – ANSI Class VI
- Sizes: 3/4", 1" (DN20, DN25)
- Body Materials: Ductile Iron, Carbon Steel, Stainless Steel
- End Connections: Threaded, Flanged
- Plug: Stainless Steel and Buna-N (DI body); Stainless Steel and Viton (CS & SS body)
- Diaphragm: Buna-N/Nylon (DI body); Viton (CS & SS body)
- Maximum Inlet Pressure: 150 psi (10 bar)
- Orifice Sizes (interchangeable): 1/4" (6mm), 5/16" (8mm); 3/8" (10mm)



## Gas Regulators

### Mark 627 Series High Pressure Regulators



The Jordan Mark 627 self-contained, pressure-reducing regulator, is designed to provide tight-shutoff and accurate regulation on low or high pressure systems. It can be used on air, natural gas or a variety of other gases. The top entry design allows for easy in-line maintenance.

- Seat: 316 Stainless Steel
- Sizes: 3/4", 1", 2" (DN20, DN25, DN50)
- Body Materials: Carbon Steel
- End Connections: FNPT (contact factory for other options)
- Orifice Sizes (Interchangeable): 3/32" (2mm), 1/8" (3mm), 3/16" (5mm), 1/4" (6mm), 3/8" (10mm), 1/2" (13mm)
- Diaphragm: Nitrile
- Service: air and gas

### Mark 630 Series High Pressure Regulators



The Jordan Mark 630 self-operated pressure reducing regulator is designed to provide tight shutoff and accurate regulation on high pressure gas systems. It can be used on air and a variety of gases. It is designed to handle inlet pressures up to 1500 psi.

- Seat: Brass or 316 Stainless Steel (CF8M)
- Sizes: 1" and 2" (DN25 and DN50)
- Body Materials: Carbon Steel (WCB A216) for 1"; Ductile Iron for 2"
- End Connections: FNPT (contact factory for other options)
- Orifice Sizes (Interchangeable): 1/8" (3mm), 3/16" (5mm), 1/4" (6mm), 3/8" (10mm), 1/2" (13mm)
- Diaphragm: Neoprene, Viton
- Disc Assembly: Brass/TFE, 316/TFE
- Service: air and gas

### Mark 687 Series Piloted Seat Regulator



The Jordan Mark 687 is a piloted soft seat regulator for critical pressure reducing applications. It uses balance plug trim with the action of a pilot valve to create a faster, more accurate (meaning less droop as your flows increase) response.

- Shutoff: ANSI Class VI
- Seat: 316SS/PTFE
- Sizes: 1-1/2" through 2" (DN40 through DN50)
- Body Materials: Carbon Steel (ASME SA216 WCB) & Stainless Steel (ASME SA351 CF8M)
- End Connections: Threaded & ANSI Flanges
- Cv (Kv): 40 (34) (1-1/2") & 50 (43) (2")

## Temperature Regulators

### Mark 80 Series Self-Operated Temperature Regulators

The Mark 80 Series is completely self-operated and requires no external power source or other expensive instrumentation to operate the valve. Depending on valve action, the seats open or close as bulb senses rise in temperature.

- Shutoff: ANSI Class IV
- Sizes: 1/4" – 2" (DN8 – DN50)
- End Connections: Threaded, Flanged, Socket Weld, Butt-Weld
- Body Materials: Ductile Iron, Bronze, Carbon Steel, Stainless Steel
- Cv (Kv): up to 30 (up to 25,8)
- Trim Materials: Stainless Steel, Monel, Hastelloy C, Alloy 20
- Seat Materials: Jorcote, Jorcote/Jordanic
- Thermal System: Seal-welded actuator (SWA) with capillary and bulb
- Control range: up to 450°F (232°C)



### Mark 801/802 Series Self-Operated High Flow Temperature Regulators

The Mark 801/802 Series is completely self-operated and requires no external power source or other expensive instrumentation to operate the valve. The Mark 801/802 Series are high-flow versions of our Mark 80 Series temperature regulators.

- Shutoff: ANSI Class IV
- Sizes: 1/2" – 2" (DN15 – DN50)
- End Connections: Threaded, Flanged, Socket Weld, Butt-Weld
- Body Materials: Ductile Iron, Bronze, Carbon Steel, Stainless Steel
- Cv (Kv): up to 70 (up to 60,2)
- Trim Materials: Stainless Steel, Monel, Hastelloy C, Alloy 20
- Seat Materials: Jorcote, Jorcote/Jordanic
- Thermal System: Seal-welded actuator (SWA) with capillary and bulb
- Control range: up to 450°F (232°C)



### Mark 85 Series “Controlled Failure” Temperature Regulator

The Mark 85 is a self-operated temperature regulator with controlled failure option which allows you to predetermine the position of the valve in the event of a thermal system failure. The Mark 85 is designed to fail closed on heating applications and to fail open on cooling applications.

- Shutoff: ANSI Class IV
- Sizes: 1/4" – 3/4" (DN8 – DN20)
- Body Materials: Ductile Iron, Bronze, Carbon Steel, Stainless Steel
- End Connections: Threaded, Flanged, Socket Weld, Butt-Weld
- Cv (Kv): up to 4.4 (up to 3,8)
- Trim Materials: Stainless Steel, Monel, Hastelloy C, Alloy 20
- Seat Materials: Jorcote, Jorcote/Jordanic
- Thermal System: Bolted Cast Iron Actuator with capillary and bulb
- Control range: up to 285°F (140°C)



## Temperature Regulators

### Mark 86 Series Steam Tracing Regulators



The Mark 86 ambitemp regulator is designed to control steam tracing lines based on ambient temperatures. The MK86 allows steam to flow through the tracer lines only when it is needed, opens or closes when ambient temperature rises above or below the setpoint depending upon action.

- Shutoff: ANSI Class IV
- Sizes: 1/2" – 2" (DN15 – DN50)
- End Connections: Threaded, Flanged, Socket Weld, Butt-Weld
- Body Materials: Ductile Iron, Bronze, Carbon Steel, Stainless Steel
- Cv (Kv): up to 30 (up to 25,8)
- Trim Materials: Stainless Steel, Monel, Hastelloy C, Alloy 20
- Seat Materials: Jorcote, Jorcote/Jordanic
- Thermal System: Seal-welded actuator (SWA)
- Control range: up to 210°F (99°C)

### Mark 87 Series External Piloted Temperature Regulators



The Mark 87 piloted temperature regulator is the Sliding Gate valve engineered to provide wide rangeability, and greater accuracy, for a variety of temperature control applications. Designed with the same technology as the Mark 80, the Mark 87 is a piloted temperature regulator that offers quality and performance.

- Shutoff: ANSI Class IV
- Sizes: 1/2" – 6" (DN15 – DN150)
- End Connections: Threaded, Flanged, Socket Weld, Butt-Weld
- Body Materials: Ductile Iron, Bronze, Carbon Steel, Stainless Steel, Cast Iron
- Cv (Kv): up to 395 (up to 339,7)
- Trim Materials: Stainless Steel, Monel, Hastelloy C, Alloy 20
- Seat Materials: Jorcote, Jorcote/Jordanic
- Thermal System: Seal-welded actuator (SWA) with capillary and bulb
- Control range: up to 450°F (232°C)

### Mark 89 Series Three-Way Temperature Regulators



The Mark 89 is used for diverting service and is ideal for bypassing fluids around coolers or filters. In this configuration, there is one inlet and two outlets. As one outlet closes, the other outlet opens, diverting flow from one channel to the other. The Mark MK89MX is ideal for mixing service.

- Shutoff: ANSI Class IV
- Sizes: 1-1/2" – 2" (DN40 – DN50)
- Body Materials: Carbon Steel, Stainless Steel
- End Connections: Threaded, Socket Weld, or Flanged
- Cv (Kv): up to 30 (up to 25,8)
- Trim Materials: Stainless Steel, Monel, Hastelloy C, Alloy 20
- Seat Materials: Jorcote, Jorcote/Jordanic
- Thermal System: Seal-welded actuator (SWA) with Capillary and bulb
- Control range: up to 450°F (232°C)

## Control Valves

### Mark 75 Series Wafer Style Sliding Gate Control Valves

With all the benefits of the time-tested Sliding Gate design, but in a lighter weight, compact wafer-style body, the Mark 75 dramatically reduces the size and weight of conventional control valves.

- Shutoff: ANSI Class IV
- Sizes: 1" – 8" (DN25 – DN200)
- Body Materials: 316 Stainless Steel, Carbon Steel
- Seat Materials: Jorcote/316SS standard; Jorcote/Jordanic/316SS opt.
- Cv (Kv): up to 600 (up to 517)
- Action: Direct (ATC) or Reverse (ATO)
- Ranges: 3-15 psi, 6-30 psi or split ranges (0,2-1,0 bar, 0,4-2,1 bar)
- ANSI Class 150/300



### Mark 70 Series Sliding Gate Control Valves

The Mark 70 Series is a line of pneumatically-operated diaphragm control valves that combine multiple spring actuators with the precision of Jordan Valve's advanced sliding gate seat for closer control and greater accuracy. Three way version available as a Mark 79. Equal percentage available as a Mark 707.

- Shutoff: ANSI Class IV
- Sizes: 1/4" – 2" (DN8 – DN50); 1/4" – 6" for Mark 711
- Body Materials: Ductile Iron, Bronze, Carbon Steel, Stainless Steel
- Seat Materials: Jorcote on SST standard; Jorcote/Jordanic on SST
- Cv (Kv): up to 30 (up to 26)
- Action: Direct (ATC) or Reverse (ATO)
- Ranges: 3-15 psi, 6-30 psi or split ranges (0,2-1,0 bar, 0,4-2,1 bar)



### Mark 701/702 Series High Flow Control Valves

The Mark 701/702 high flow sliding gate control valves provide higher Cv without going to a larger valve, straight through flow and ease of maintenance

- Shutoff: ANSI Class IV
- Sizes: 1/2" – 2" (DN15 – DN50)
- Body Materials: Ductile Iron, Bronze, Carbon Steel, Stainless Steel
- Seat Materials: Jorcote on SST standard; Jorcote/Jordanic on SST
- Cv (Kv): up to 70.0 (up to 60,3)
- Action: Direct (ATC) or Reverse (ATO)
- Ranges: 3-15 psi, 6-30 psi or split ranges (0,2-1,0 bar, 0,4-2,1 bar)



## Sliding Gate Control Valves

### Mark 33 Series Electric Motor Control Valves

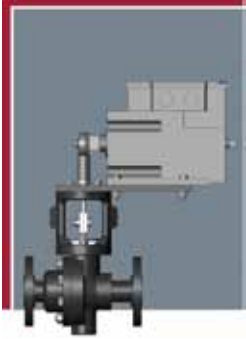

The Mark 33 is a motor operated valve featuring the Jordan sliding gate seat and heavy-duty industrial motors for proportional (resistance), on-off, or 4-20mA electronic format. The Mark 331/332 is the High Flow version of this valve, and the Mark 337 is the equal percentage version.

- Shutoff: ANSI Class IV
- Sizes: 1/4" – 2" (DN8 – DN50)
- Body Materials: Ductile Iron, Bronze, Carbon Steel, Stainless Steel
- End Connections: Threaded, Flanged, Socket Weld, Butt-Weld
- Cv (Kv): up to 30 (up to 25,9)
- Trim Materials: Stainless Steel, Monel, Hastelloy C, Alloy 20
- Seat Materials: Jorcote, Jorcote/Jordanic
- Command Signals: Proportional (resistance), on/off, milliamp, or 2-10 VDC

### Mark 37 Series Final Control Element Valve

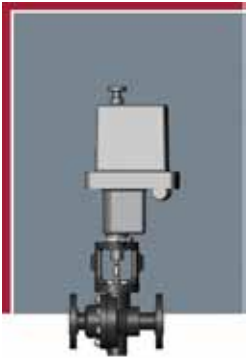

The Mark 37 is a motor-operated control valve that combines a state-of-the-art electronic linear actuator with the exceptional performance of Jordan's sliding gate seat design. The result is a superior degree of accuracy that makes it ideal for use as the final control element in distributed process control systems. The Mark 371/372 is the High Flow version of this valve, and the Mark 377 is the equal percentage version.

- Shutoff: ANSI Class IV
- Sizes: 1/4" – 6" (DN8 – DN150)
- Body Materials: Ductile Iron, Bronze, Carbon Steel, Stainless Steel, Cast Iron
- End Connections: Threaded, Flanged, Socket Weld, Butt-Weld
- Cv (Kv): up to 395 (up to 339,7)
- Trim Materials: Stainless Steel, Monel, Hastelloy C, Alloy 20
- Seat Materials: Jorcote, Jorcote/Jordanic
- Command Signals: Current or voltage command, on/off

### Mark 74 Series Bellows Seal Control Valve



The Mark 74 provides exceptional bellows life with a valve stroke that is just a fraction of that of other rising stem valves. This means Jordan Valve can use a smaller formed bellows that has minimal movement during operation.

- Shutoff: ANSI Class IV
- Sizes: 1/4" – 2" (DN8 – DN50)
- Body Materials: Ductile Iron, Bronze, Carbon Steel, Stainless Steel
- Seat Materials: Jorcote/316SS standard; Jorcote/Jordanic/316SS opt.
- Cv (Kv): up to 30 (up to 10,3)
- Action: Direct (ATC) or Reverse (ATO)
- Ranges: 3-15 psi, 6-30 psi or split ranges (0,2-1,0 bar, 0,4-2,1 bar)

## Control Valves

### Mark 78 Series Globe Style Control Valves

The Mark 78 pneumatic control valve is designed for accurate performance and simplified maintenance. This versatile product can be used on a variety of applications, including viscous/corrosive liquids, process gases or steam in process or utility service.

- Shutoff: ANSI Class IV or VI
- Sizes: 1/2" – 2" (DN15 – DN50)
- End Connections: Threaded, Flanged, Socket Weld, Butt-Weld
- Body Materials: Bronze, Carbon Steel, Stainless Steel
- Cv (Kv): up to 50 (up to 43)
- Trim Materials: Stainless Steel, Monel, Hastelloy C, Alloy 20
- Seat: ANSI Class IV (Hard Seat); ANSI Class VI Teflon (Soft Seat)
- Control Ranges: 3-15 psi, 6-30 psi or split ranges (0,2-1,0 bar, 0,4-2,1 bar)



### V1C Series Cage-Guided Control Valve/V1S Stem Guided Control Valve

The V1C cage-guided balanced trim control valve offers high pressure capability and tight shutoff with the use of standard spring/diaphragm actuators. The V1C contains a cage that is characterized in order to allow equal percentage and linear flow characteristics.

- Shutoff: ANSI Class III, IV or VI
- Sizes: 1-1/2" – 6" (DN40 – DN150)
- Body Materials: Carbon Steel, Stainless Steel
- End Connections: Threaded, Socket Weld or Flanged
- Cv (Kv): up to 400 (up to 344)
- Trim Materials: Stainless Steel
- Bonnet Types: Plain, Extended, Bellows Seal
- Control Ranges: 3-15 psi or split ranges with side mounted positioner.



### Mark 2000 Series Angle Seat On/Off Control Valves

The Mark 2000 is an externally piloted angle-seat valve with self-adjusting packing gland, intermediate relief and wiper. The angle-seat construction of the body makes possible extremely high flow rates, particularly in comparison to conventional globe valves.

- Seat: PTFE
- Sizes: 1/2" – 2" (DN15 – DN50)
- Body Materials: 316 SST
- End Connections: Threaded (NPT)
- Pressure Range: 0 – 362 psi, max (0 – 25 bar)
- Trim Materials: 304 SST
- Packing Materials: Spring loaded, PTFE-V Rings
- Solenoid Options: 125VAC or 24 VDC





*Please refer to the Steriflow Condensed Catalog for information relating to our complete line of sanitary pressure regulators, back pressure regulators, control valves, ball valves, steam traps and high purity pressure regulators. Please refer to our LowFlow Condensed Catalog for information relating to our complete line of fractional flow control valves and regulators.*



## RICHARDS INDUSTRIES

Richards Industries is the parent company of six distinct industrial product lines:

- **Jordan Valve** – Pressure and temperature regulators; pneumatic and electric control valves
- **Steriflow Valve** – Sanitary regulators, control valves and steam traps
- **LowFlow Valve** – Fractional flow control valves and regulators
- **Marwin Valve** – Ball valves and automated products
- **Hex Valve** – Instrumentation valves and manifolds
- **Bestobell Steam Traps** – Steam traps and steam specialty equipment

Our global network of representatives and distributors is our customers' most valuable resource. With over 200 representatives throughout the world, there is a local rep who will provide hands-on assistance with your application.

**To learn more about Richards Industries and our products visit: [www.richardsind.com](http://www.richardsind.com)**

ISO 9001: 2000 certified

3170 Wasson Road  
Cincinnati, OH 45209  
USA

513-533-5600 • 513-871-0105 (f)

[info@richardsind.com](mailto:info@richardsind.com)  
[www.jordanvalve.com](http://www.jordanvalve.com)